

# ProfitMilling<sup>TM</sup>

Putting **you** on the right path

## ESPRIT ProfitMilling<sup>TM</sup> | A Technical Overview

### Contents

<i>ProfitMilling<sup>TM</sup>: What is it?</i>	2
<i>Benefits to Manufacturers</i>	2
<i>Traditional Roughing Limitations</i>	3
<i>ProfitMilling<sup>TM</sup> Advantages</i>	4
<i>Benefits of ProfitMilling<sup>TM</sup></i>	5
<i>Energy Consumption</i>	5
<i>Parameters for Optimized Machining</i>	6
<i>Test Results</i>	6
<i>Example 1</i>	6
<i>Example 2</i>	7
<i>Example 3</i>	8
<i>Conclusion</i>	9

## ***ProfitMilling: What is it?***

The ProfitMilling™ roughing strategy is a high-speed material-removal cycle that allows programmers to take a significantly deeper, faster and more efficient cut while reducing wear on the tool and machine.

The ProfitMilling™ algorithm (which is a unique, patent-pending method for calculating toolpath) was developed to take both tool-engagement angle and constant step-over into consideration. Rather than controlling just one parameter, ProfitMilling™ monitors several vital cutting and machine characteristics. The ProfitMilling™ toolpath manages chip load (the thickness of a chip formed during the machining of the material) and side-cutter force in the calculation of toolpath while keeping the engagement angle (the angular measurement of the edge of the cutting tool that is in contact with the material being removed) and material removal rate within a specific range.

It also incorporates dynamic feedrate changes throughout the toolpath and takes advantage of toolpath optimization for specific machine capabilities, such as machine acceleration and deceleration.

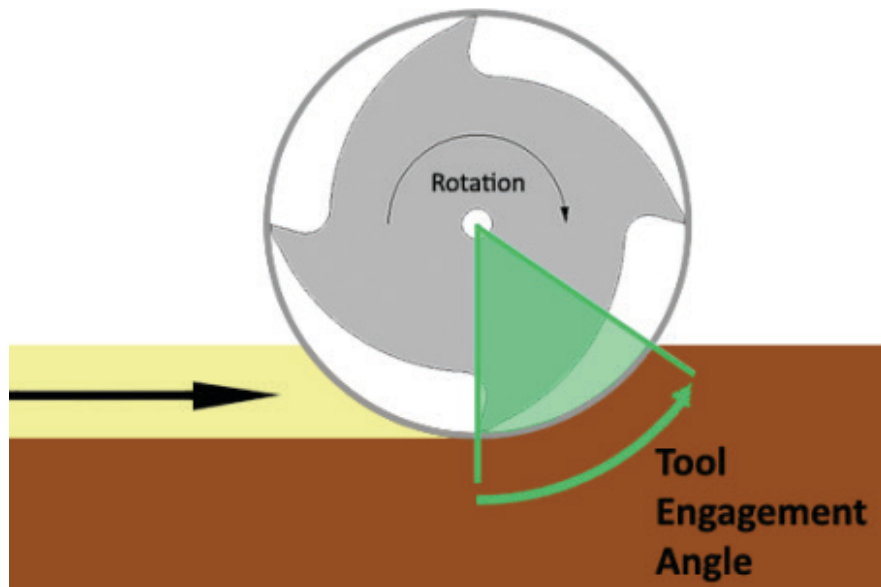

## ***Benefits to Manufacturers***

Manufacturers are constantly challenged with intense competition and are continuously in search of new means with which to produce quality parts within shorter periods of time, and at reduced cost.

The benefits of the ProfitMilling™ cycle are a reduction in machine-tool cycle times, increased tool life, decreased programming time, reduced energy consumption and significant productivity improvements — even with light and medium-duty machine tools.

Initial tests cuts were first performed at the University of California, Davis, research lab, along with analyses conducted with customers and machine-tool partners. Test results have shown that ProfitMilling™ typically reduces cycle time by 75 percent compared to a traditional concentric roughing strategy.

## Traditional Roughing Limitations

Traditional roughing toolpath is laden with limitations, such as sharp corners and high engagement angles that significantly increase the width of the tool's cutting area. For example, the cutting tool can become fully engaged in the material along the first cutting pass of a roughing operation and in any slots that are only slightly wider than the cutter. A tool is typically considered fully engaged when it is cutting material on both sides of the tool (100 percent of the tool radius).

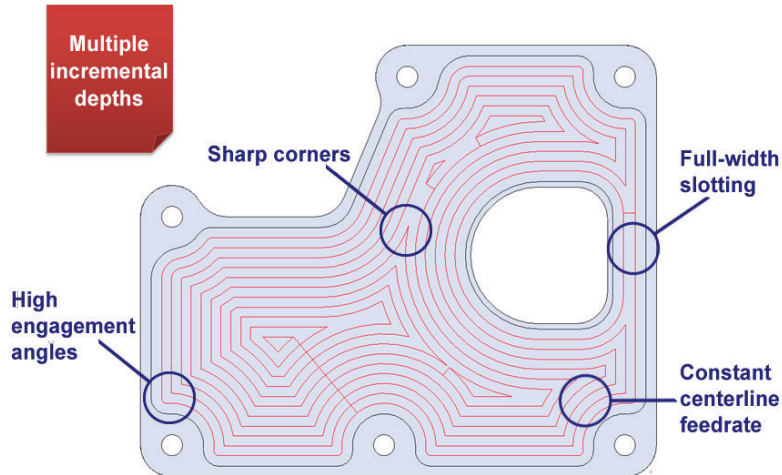

### Traditional Pocketing Limitations

Full engagement of the tool can also occur when moving from a straight cut into areas where there is a sharp transition in the cutter path, such as a corner. This causes the cutting tool to be overloaded, resulting in reduced tool life or, in some cases, tool breakage. Conservative feedrates must be used along the entire toolpath and cutting depth generally needs to be significantly reduced to avoid tool damage.

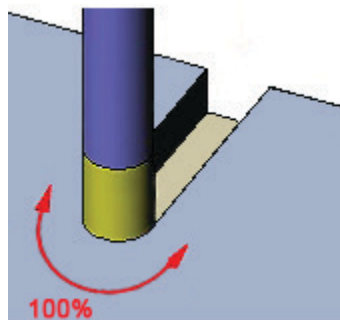

Additionally, traditional toolpath calculates the feed rate required based on the centerline of the tool. When cutting a linear tool movement, the feedrate at the cutting edge and centerline are identical. With circular tool movement, however, this is not the case. The laws of physics tell us that, when milling in a circular path, the outside diameter of the cutter is moving at a rate different than that of the cutting tool's centerline. All of the abovementioned limitations force parts to be cut conservatively to account for these inconsistencies.

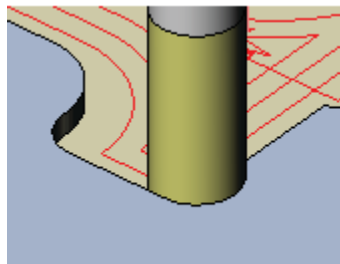

## ProfitMilling™ Advantages

ProfitMilling™ removes the restrictions of traditional roughing toolpath. Sharp corners are replaced with smooth toolpath blending and transitions. Trochoidal slotting strategy is applied to replace full-width slotting, and instead of employing constant centerline feedrate, dynamic feedrate changes are incorporated throughout the toolpath. By maintaining a very consistent tool load, so as not to exceed a specified amount, the feedrate is easily optimized to maximum potential. ProfitMilling™ also takes advantage of corner picking, or the practice of removing less material in corners, which eliminates chatter and keeps a constant tool-engagement angle. Likewise, it optimizes transitional moves with small Z-directional lifts to prevent the tool from dragging on the machined surface and thus reduce tool drag. As a result of these enhancements, a significantly deeper, faster and more efficient cut can be made while dramatically reducing cycle time because the toolpath keeps the tool operating near its capacity.

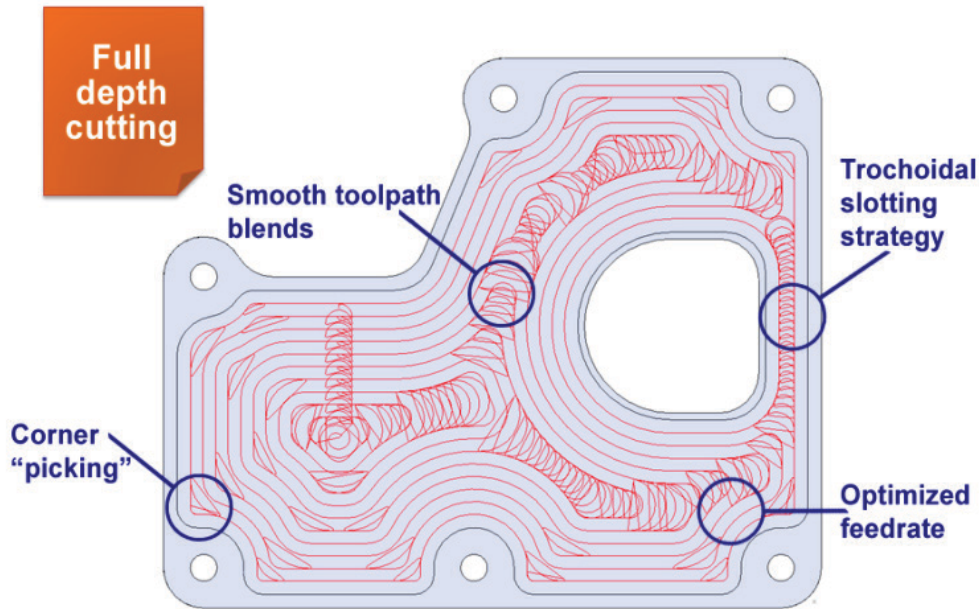

## ProfitMilling Advantages

A manageable chip load and predictable cutting forces put less stress on the cutting tool and machine-tool, which add another significant benefit. Managing chip load also generates chips to an appropriate size, enabling the heat to be carried away by the chip. If the chip is too small, the heat is transferred to the cutting tool, reducing tool life. If the chip load is too high, tool deflection can occur. Thus, an increase in tool life and potential rise in accuracy are achievable due to managing chip load.

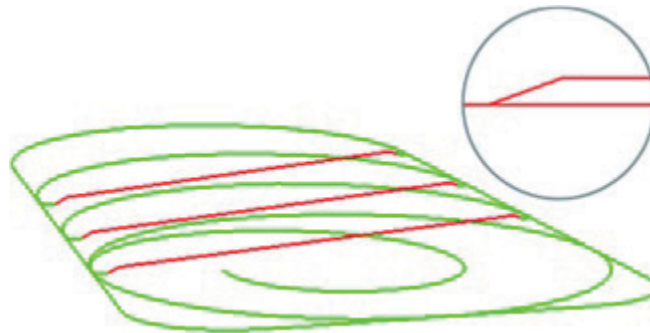

## Benefits of ProfitTurning™

### Improve tool life and surface quality.

CNC tooling can be quite expensive and tool life is extended when a tool consistently cuts at a constant chip load. This ensures that the tool is never buried in the material, eliminating tool chatter and the risk of breaking expensive cutters. The cutting edge is only in contact with the material through roughly 5 percent of the cutter's revolution versus up to 50 percent with traditional cutting passes. This small engagement allows the majority of the tool's revolution to cool the tool, and the heat is dissipated into the chip. The simple fact that you spend less time changing tools is a savings.

### Optimize productivity by roughing parts as quickly as possible.

The elimination of sharp changes in tool direction allows for consistently faster feedrates.

### Maximize part production.

Machine hardened materials, parts with thin walls for which tool pressure is a factor, and utilize the full capabilities of high-speed machining centers.

### Extend machine life.

With less pressure and vibration from the tool, machine life is extended and maintenance costs reduced.

### Increase efficiency with existing equipment.

Cut at faster feedrates, faster spindle speeds, at greater depths of cut than traditional machining, even with older machines or machines with low horsepower or smaller spindle connections.

ProfitMilling™ is available for 2 ½, 3, 4, and 5-axis machining strategies, which allows for a full range of milling applications.

## Energy Consumption

By decreasing machine-tool cycle time, a significant reduction in energy consumption by the machine-tool is obtained. The energy consumption for an automated milling machine can be broken down into three operational categories: constant, run-time and material removal.

This energy usage breakdown can be seen in the figure to the right. Typically 60-70 percent of power requirements for the machine-tool are for non-cutting machine processes, and the energy necessary to actually cut the material is only a small portion of the total amount of energy required in machining. Therefore, any reduction in cycle time equates to a proportionate drop in energy consumption.

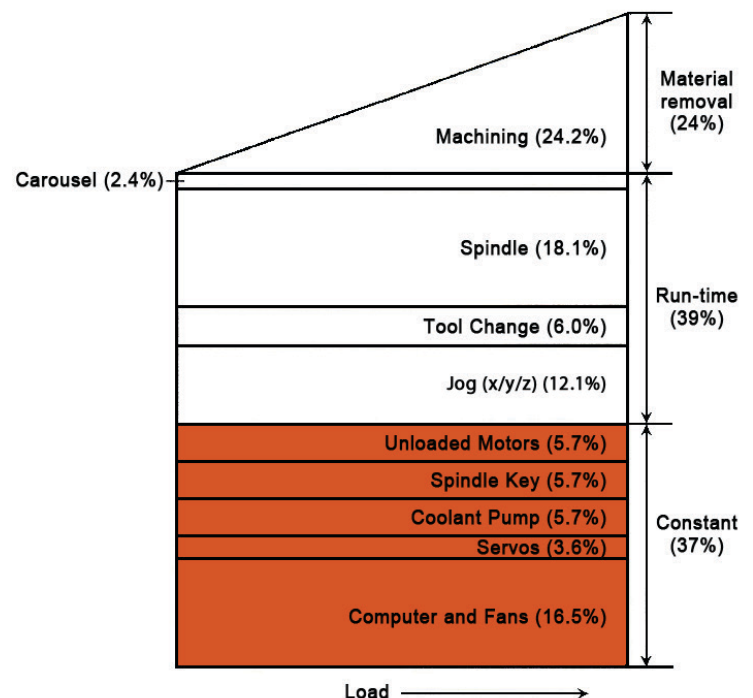

## Parameters for Optimized Machining

Feedrates can typically be doubled or tripled and most parts can be cut at a depth of two times the tool diameter. Increasing the depth will result in better tool life because the tool wear is spread out over the entire length of the cutter.

The following factors affect performance:

### Flute count:

Whenever possible, use tools with a high flute count for a higher feedrate. However, the possibility of chip buildup must be balanced against a higher possible feedrate.

### Coolant:

Coolant is generally discouraged, as its use can increase thermal shock on the cutting edge. The ProfitMilling toolpath puts most of the generated heat into the chip and away from the part and tool. High pressure air may be helpful, as it aids in chip evacuation.

### Machine horsepower, tooling, material, and machining strategy:

These conditions determine whether it is better to use an aggressive radial engagement with slower feedrates or a smaller radial engagement at faster feedrates.

### Machine acceleration/deceleration:

How the machine handles acceleration/ deceleration of interpolated movements affects performance.

## Test Results: Example 1

<b>Location</b>	Mazak, USA, Florence, KY
<b>Part</b>	4140 Steel (Pre-Hardened), 30 HRC
<b>Machine Tool</b>	Mazak Nexus 510 C
<b>Cutting Tool Insert</b>	Oak View Tool T1162-500-2.4-030 1/2 inch carbide, 6-flute endmill
<b>Cutter Diameter (in)</b>	0.315
<b>Tool Motion Pattern</b>	ProfitMilling™
<b>Spindle Speed</b>	10,000 RPM
<b>Feed Rate, IPM</b>	360
<b>Depth of Cut (in)</b>	1.00
<b>Engagement Angle</b>	30° (7% stepover)
<b>Chipoad</b>	0.006 IPT
<b>Coolant</b>	Air blast
<b>Cutting Speed</b>	1309 SFM
<b>Results</b>	<b>Cycle Time:</b> 3m 32s <b>Tool Wear:</b> 5 Parts/Tool <b>Volume Removed:</b> 51.47 in <sup>3</sup> <b>MRR:</b> 1,2600 in <sup>3</sup> /min

Images

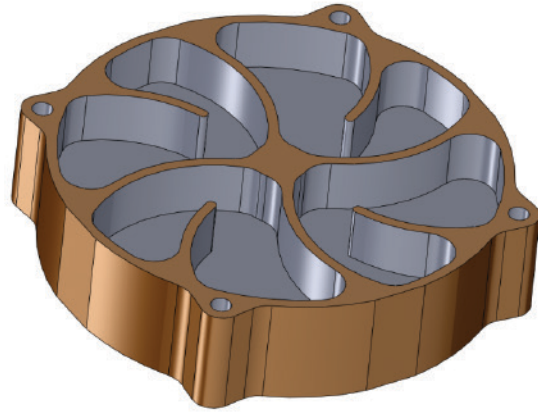

## Test Results: Example 2

Location	Single Source, Inc. North Liberty, IN
Part	17-4 Stainless Steel, ~25 HRC
Machine Tool	Mori Seiki NT 1000 W
Cutting Tool Insert	Oak View Tool TI-Series 3/8 inch 6-flute endmill
Cutter Diameter (in)	0.315
Tool Motion Pattern	ProfitMilling™
Spindle Speed	6,112 RPM
Feed Rate, IPM	147
Depth of Cut (in)	0.50
Engagement Angle	26° (5% stepover)
Chipoad	0.004 IPT
Coolant	No
Cutting Speed	600 SFM
Results	<b>Cycle Time:</b> 1m 30s <b>Tool Wear:</b> 100 + Parts/Tool <b>Volume Removed:</b> 0.72 in <sup>3</sup> <b>Peak MRR:</b> 1.38 in <sup>3</sup> /min <b>Avg. MRR:</b> 0.48 in <sup>3</sup> /min

Images



### Test Results: Example 3

<b>Location</b>	Morris Great Lakes, Cranberry Township, PA
<b>Part</b>	Alloy Steel, 35 HRC, 8" x 5.7", 1.0" depth
<b>Machine Tool</b>	Okuma Genos M460-VE Vertical Mill
<b>Cutting Tool Insert</b>	Sandvik Plura RA216.24-3250BAK24P 1620, 1/2 inch carbide, 4-flute endmill
<b>Cutter Diameter (in)</b>	0.315
<b>Tool Motion Pattern</b>	ProfitMilling™
<b>Spindle Speed</b>	4,202 RPM
<b>Feed Rate, IPM</b>	205
<b>Depth of Cut (in)</b>	1.00
<b>Engagement Angle</b>	34.5° (9% stepover)
<b>Chipoad</b>	0.0122 IPT
<b>Coolant</b>	No
<b>Cutting Speed</b>	550 SFM
<b>Results</b>	<b>Cycle Time:</b> 27m 22s <b>Parts/Tool:</b> 5 <b>Volume Removed:</b> 38.86 in <sup>3</sup> <b>Peak MRR:</b> 9.02 in <sup>3</sup> /min <b>Avg. MRR:</b> 1.42 in <sup>3</sup> /min
<b>Images</b>	



## Conclusion

The benefits of the ProfitMilling™ cycle are a reduction in machine-tool cycle times, increased tool life, decreased programming time, reduced energy consumption and significant productivity improvements — even with light and medium-duty machine tools. By holding cutting parameters at an optimal level, maximum material removal rate is attained and greater profits realized. While ProfitMilling™ toolpath may look similar to those offered by other computer-aided-manufacturing (CAM) systems, it's important to remember that a toolpath is much more than a tool position and that dynamic feedrate is vital to toolpath capabilities.

\*Source: Dahmus, J. Applications of Industrial Ecology: Manufacturing, Recycling, and Efficiency. Cambridge, MA: Dept. Mech. Eng., Massachusetts Institute of Technology; 2007.



### About ESPRIT

ESPRIT is a global leader in high-performance computer aided manufacturing (CAM) Software. ESPRIT is a cloud-enabled CAD/CAM software compatible with a full range of machine tool applications in a wide array of industries. ESPRIT delivers powerful full-spectrum programming for 2-5 axis milling, 2-22 axis turning, wire EDM, multitasking, mill-turn, Swiss-turn and B-axis machine tools, and high-speed 3 and 5 axis machining. Offering factory certified post processors, accurate G-code, and world-class customer support ESPRIT is the ultimate machine tool solution.

### About DP Technology Corp.

DP Technology Corp., maker of ESPRIT CAD/CAM software, maintains its worldwide headquarters in Camarillo, California, and product development teams in California, Florence, Italy, and Berlin, Germany. Sales and support operations are located in Europe, Asia, and North and South America.

For additional information about DP Technology and ESPRIT, call +1 805 388 6000, send an email to [esprit@dptechnology.com](mailto:esprit@dptechnology.com), or visit the company website at [www.espritcam.com](http://www.espritcam.com).